

Shaft Type Ø50mm Incremental Rotary Encoder

■ Features

- Suitable for measuring angle, position, revolution, speed, acceleration and distance
- Power supply: 5VDC, 12-24VDC ±5%

■ Applications

- Various tooling machinery, packing machine and general industrial machinery, etc.



⚠ Please read "Safety Considerations" in the instruction manual before using.



■ Ordering Information (former name: ENB)

E50S	8	8000	3	N	24	
Series	Shaft diameter	Pulses/revolution	Output phase	Control output	Power supply	Cable
Ø50mm, shaft type	Ø8mm	Refer to resolution	2: A, B 3: A, B, Z 4: A, \bar{A} , B, \bar{B} 6: A, \bar{A} , B, \bar{B} , Z, Z	T: Totem pole output N: NPN open collector output V: Voltage output L: Line driver output	5: 5VDC ±5% 24: 12-24VDC ±5%	No mark: Axial cable type C: Axial cable connector type CR: Axial connector type CS: Radial connector type

■ Specifications

Item	Shaft Type Ø50mm Incremental Rotary Encoder		
Resolution (PPR) ^{*1}	*1, *2, *5, 10, 12, 15, 20, 23, 25, 30, 35, 40, 45, 50, 60, 75, 100, 120, 125, 150, 192, 200, 240, 250, 256, 300, 360, 400, 500, 512, 600, 800, 1000, 1024, 1200, 1500, 1800, 2000, 2048, 2500, 3000, 3600, 4000, 5000, 6000, 8000		
Electrical specification	Output phase	A, B, Z phase (line driver: A, A, B, B, Z, Z phase)	
	Phase difference of output	Output between A and B phase: $\frac{T}{4} \pm \frac{T}{8}$ (T=1 cycle of A phase)	
	Control output	Totem pole output	• [Low] - Load current: max. 30mA, residual voltage: max. 0.4VDC= • [High] - Load current: max. 10mA, output voltage (power voltage 5VDC= \pm): min. (power voltage-2.0)VDC= \pm , output voltage (power voltage 12-24VDC= \pm): min. (power voltage-3.0)VDC= \pm
		NPN open collector output	Load current: max. 30mA, residual voltage: max. 0.4VDC= \pm
		Voltage output	Load current: max. 10mA, residual voltage: max. 0.4VDC= \pm
	Line driver output		• [Low] - Load current: max. 20mA, residual voltage: max. 0.5VDC= \pm • [High] - Load current: max. -20mA, Output voltage (power voltage 5VDC= \pm): min.2.5VDC= \pm , Output voltage (power voltage 12-24VDC= \pm): min. (power voltage-3.0)VDC= \pm
		Totem pole output	Max. 1 μ s (cable length: 2m, I sink = 20mA)
		NPN open collector output	
	Voltage output		
	Response time (rise/fall)	Line driver output	Max. 0.5 μ s (cable length: 2m, I sink = 20mA)
Max. response frequency	300kHz		
Power supply	• 5VDC= \pm 5% (ripple P-P: max. 5%) • 12-24VDC= \pm 5% (ripple P-P: max. 5%)		
Current consumption	Max. 80mA (disconnection of the load), Line driver output: max. 50mA (disconnection of the load)		
Insulation resistance	Over 100M Ω (at 500VDC megger between all terminals and case)		
Dielectric strength	750VAC 50/60Hz for 1 minute (between all terminals and case)		
Connection	Axial cable type, Axial cable connector type, Axial/Radial connector type		
Mechanical specification	Starting torque	Max. 70gf·cm (0.007N·m) ^{*2} , max. 800gf·cm (0.078N·m) ^{*3}	
	Moment of inertia	Max. 80g·cm ² (8×10 ⁻⁶ kg·m ²) ^{*2} , max. 400g·cm ² (4×10 ⁻⁵ kg·m ²) ^{*3}	
	Shaft loading	Radial: max. 10kgf, Thrust: max. 2.5kgf	
	Max. allowable revolution ^{*4}	5,000rpm	
Vibration	1.5mm amplitude at frequency of 10 to 55Hz in each X, Y, Z direction for 2 hours		
Shock	Approx. max. 75G		
Environment	Ambient temperature	-10 to 70°C, storage: -25 to 85°C	
	Ambient humidity	35 to 85%RH, storage: 35 to 90%RH	
Protection structure	Axial cable type, Axial cable connector type: IP50 (IEC standard) ^{*5} , Axial/Radial connector type: IP65 (IEC standard)		
Cable	Ø5mm, 5-wire (line driver output: 8-wire), 2m, Shield cable (AWG 24, core diameter: 0.08mm, number of cores: 40, insulator out diameter: Ø1mm)		
Accessory	Ø8mm coupling, bracket		
Approval	CE (except for line driver output)		
Weight ^{*6}	Approx. 363g (approx. 275g), Axial/Radial connector type: approx. 268g (approx. 180g)		

※1: "*" pulse is only for A, B phase (line driver output is for A, \bar{A} , B, \bar{B} phase). Not indicated resolutions are customizable.

※2: This value is for Axial cable type, Axial cable connector type (protection structure: IP50).

※3: This value is for Axial cable type, Axial cable connector type (protection structure: IP64),

Axial/Radial connector type (protection structure: IP65).

※4: Make sure that max. response revolution should be lower than or equal to max. allowable revolution when selecting the resolution.

$$\text{【Max. response resolution (rpm) = } \frac{\text{Max. response frequency}}{\text{Resolution}} \times 60 \text{ sec } \text{】}$$

※5: In case of axial cable type, axial cable connector type, they are available to order the option protection structure IP64.

※6: The weight includes packaging. The weight in parenthesis is for unit only.

※Environment resistance is rated at no freezing or condensation.

SENSORS

CONTROLLERS

MOTION DEVICES

SOFTWARE

(A) Photoelectric Sensors

(B) Fiber Optic Sensors

(C) LIDAR

(D) Door/Area Sensors

(E) Vision Sensors

(F) Proximity Sensors

(G) Pressure Sensors

(H) Rotary Encoders

(I) Connectors/ Connector Cables/ Sensor Distribution Boxes/ Sockets

E50S Series

Control Output Diagram

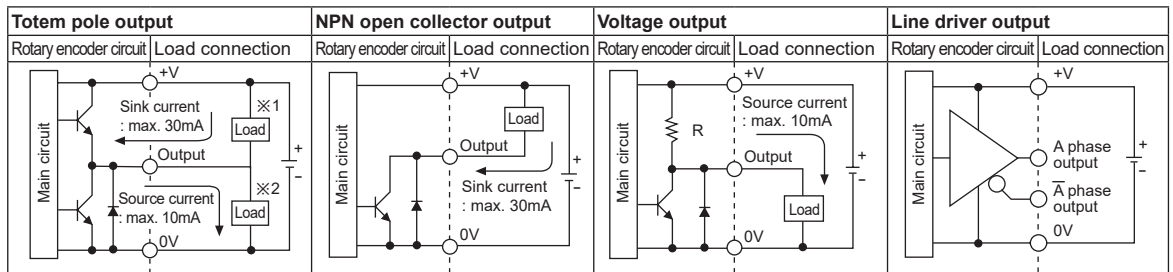

- All output circuits of A, B, Z phase are same. (line driver output is A, \bar{A} , B, \bar{B} , Z, \bar{Z})
- Totem pole output type can be used for NPN open collector type(×1) or voltage output type(×2).

Output Waveforms

- Totem pole output / NPN open collector output / Voltage output

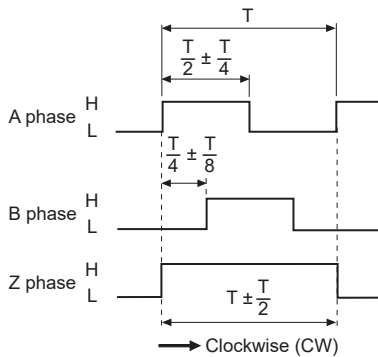

- Line driver output

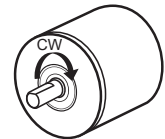
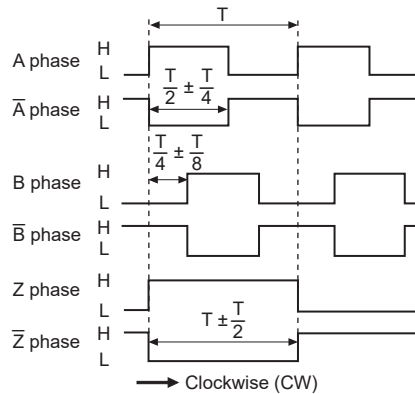

Connections

⊙ Axial cable type

- Totem pole output / NPN open collector output / Voltage output

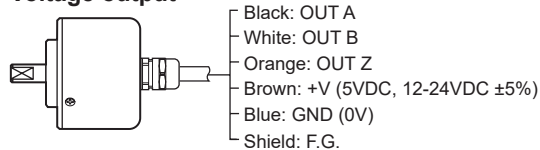

- Line driver output

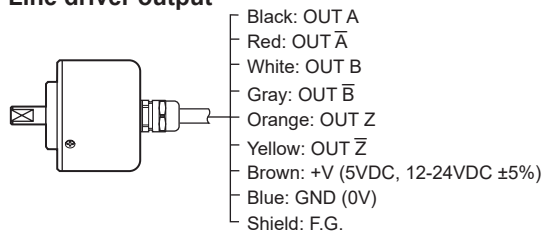

- ⊗ Unused wires must be insulated.
- ⊗ The metal case and shield cable of encoder should be grounded (F.G.).
- ⊗ Do not apply tensile strength over 30N to the cable.

⊙ Axial cable connector type / Axial/Radial connector type

- Totem pole output / NPN open collector output / Voltage output
- Line driver output



Pin No.	Cable color	Function
1	Black	OUT A
2	White	OUT B
3	Orange	OUT Z
4	Brown	+V
5	Blue	GND
6	Shield	F.G.



Pin No.	Cable color	Function
1	Black	OUT A
2	Red	OUT A-bar
3	Brown	+V
4	Blue	GND
5	White	OUT B
6	Gray	OUT B-bar
7	Orange	OUT Z
8	Yellow	OUT Z-bar
9	Shield	F.G.

- ⊗ F.G. (field ground): It should be grounded separately.

Incremental Ø50mm Shaft Type

■ Dimensions

(unit: mm)

◎ Axial cable type, Axial cable connector type (IP50)

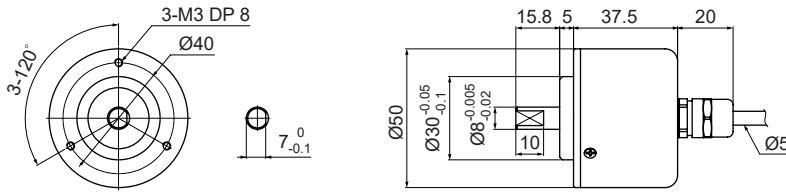

Cable for Axial cable type
Ø5mm, 5-wire (line driver output: 8-wire), Leng h: 2m, Shield cable
Cable for Axial cable connector type (M17×1)
Ø5mm, 5-wire (line driver output: 8-wire), Leng h: 250mm, Shield cable

◎ Axial cable type, Axial cable connector type (IP64) (option)

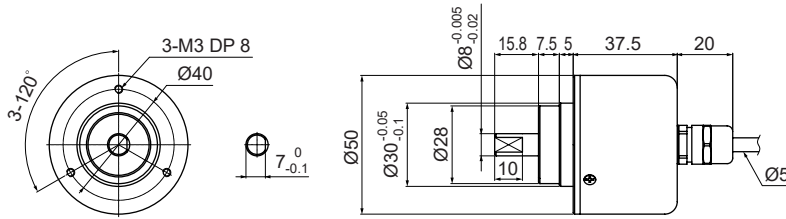

Cable for Axial cable type
Ø5mm, 5-wire (line driver output: 8-wire), Leng h: 2m, Shield cable
Cable for Axial cable connector type (M17×1)
Ø5mm, 5-wire (line driver output: 8-wire), Leng h: 250mm, Shield cable

◎ Axial connector type

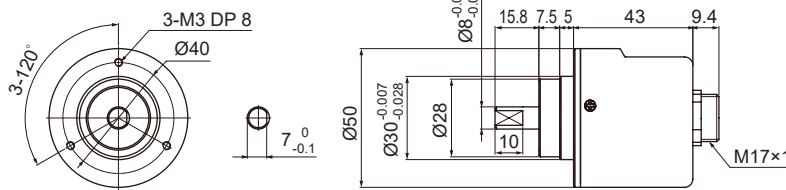

◎ Radial connector type

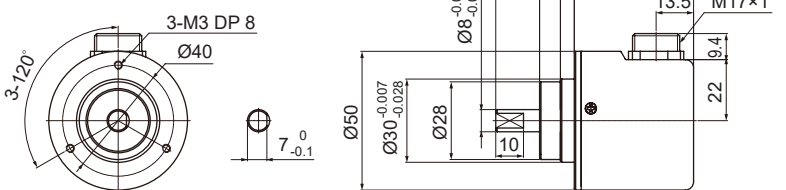

※Connector cable is sold separately and refer to the 'Connectors, Connector Cables, Sensor Distribution Boxes, Sockets' section.

◎ Coupling

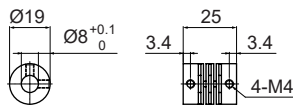

- Parallel misalignment: max. 0.25mm
- Angular misalignment: max. 5°
- End-play: max. 0.5mm

※Do not load overweight on the shaft.

※Do not put strong impact when insert a coupling into shaft.

Failure to follow this instruction may result in product damage.

※Fix the unit or a coupling by a wrench under 0.15N·m of torque.

※When you install this unit, if eccentricity and deflection angle are larger, it may shorten the life cycle of this unit.

※For parallel misalignment, angular misalignment, end-play terms, refer to the "Glossary" section of Technical Description.

※For flexible coupling (ERB series) information, refer to the ERB series section.

◎ Bracket

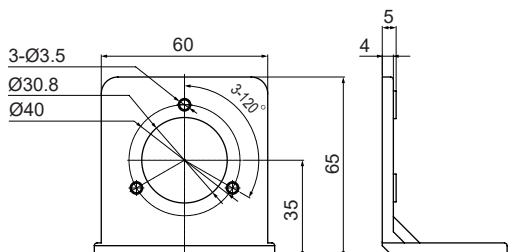
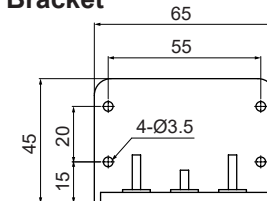

SENSORS

CONTROLLERS

MOTION DEVICES

SOFTWARE

(A) Photoelectric Sensors

(B) Fiber Optic Sensors

(C) LIDAR

(D) Door/Area Sensors

(E) Vision Sensors

(F) Proximity Sensors

(G) Pressure Sensors

(H) Rotary Encoders

(I) Connectors/
Connector Cables/
Sensor Distribution
Boxes/ Sockets